

---

---

SPECIFICATION FOR

**SERVICE TERMINATIONS**

---

---

*Uncontrolled when printed.  
Complies with GRM.*



---

**CONTENTS**

	<b>Page</b>
FOREWORD	ii
1. INTRODUCTION	1
2. SCOPE	1
3. SERVICE PIPE DESIGN & TERMINATION	1
<b>APPENDICES</b>	
A REFERENCES	4
B DEFINITIONS	5
C SPECIFICATION AND DETAILS OF ECV INSTALLATION	6

*Uncontrolled when printed.  
Complies with GRM.*

## FOREWORD

This document was approved by GNSEC for use by managers, engineers and supervisors throughout Northern Gas Networks Limited (NGN).

NGN documents are revised, when necessary, by the issue of new editions. Users should ensure that they are in possession of the latest edition by referring to the NGN Register of safety and engineering documents available on the company Intranet.

Compliance with this safety and engineering document does not confer immunity from prosecution for breach of statutory or other legal obligations.

## DISCLAIMER

This safety and engineering document is provided for use by NGN and such of its contractors as are obliged by the terms and conditions of their contracts to comply with this document. Where this document is used by any other party it is the responsibility of that party to ensure that this document is correctly applied.

## MANDATORY AND NON-MANDATORY REQUIREMENTS

In this document:

**must:** indicates a mandatory requirement.

**should:** indicates best practice and is the preferred option. If an alternative method is used then a suitable and sufficient risk assessment must be completed to show that the alternative method delivers the same, or better, level of protection.

## BRIEF HISTORY

Reviewed and first published	July 2007.
------------------------------	------------

Uncontrolled when printed.  
Complies with GRM.

---

# SPECIFICATION FOR SERVICE TERMINATIONS

## 1. INTRODUCTION

In support of the introduction of competition in the provision of gas supply metering installations NGN has prepared standard service pipe termination details. These details provide service and meter installers with the orientation and location dimensions, and define the position of the Emergency Control Valve (ECV) for all new standard installations. The standards also define the size and type of ECV thread or flange outlet fitting.

## 2. SCOPE

This Specification applies to all services to metering installations where the inlet pressure is equal or less than 7bar. The document illustrations are shown as standard examples; the use of PE / Steel transition fitting is the preferred option when a service entry is made to external meter houses. The service height and entry dimensions shall also be adopted for all internal installations where permitted (including MP/IP).

N.B. a variation in heights and dimensions shown is permitted when it is unsound, unsafe or impractical to install the termination as indicated.

General requirements for PE service entries into buildings should be made to IGE/TD/3 and IGE/TD/4.

This document excludes standard domestic service termination into prefabricated recess, surface mounted and semi-concealed meter boxes.

## 3. SERVICE PIPE DESIGN & TERMINATION

### 3.1 Planning

The size of a gas service pipe should be determined for gas supply points in accordance with NGN/SP/NP/14.

Due consideration of the requirements of the relevant Building Regulations, GS(I&U) Regulations, BS 6400 and IGE/GM/6 and IGE/GM/8 for acceptable meter locations, should be taken into account when agreeing the proposed final meter positions. In accordance with NGN/SP/NP/14, allowance for the specific service termination fittings should be taken into account for calculation purposes.

### 3.2 Specification for the ECV

To provide a predictable consistent installation and ensure that independent meter installers can make a connection to the gas service pipe, an ECV of nominal size and type as indicated within Table A1 – A3 shall be provided. The specifications of the meter inlet connection details are also given in Tables A1 – A3.

### 3.3 ECV orientation and Position

Service entries and emergency control valves should be installed to the left of the meter installation viewed from a front elevation.

The ECV shall be operated by a key, lever or hand wheel, which should be securely attached to the operating spindle. Where a key or lever is used, the 'open' position should be when the key or lever is parallel to the axis of the pipe. Where the key or lever moves in the vertical plane, the move to the off position should be in a downward direction.

The ECV shall be located relative to the external walls of any kiosk / meter room (with a service slot through the base of the kiosk where used), as shown within the figures in Appendix C.

Note: Above ground entries for services exceeding 6" nominal bore shall not be used, and all such installations shall be provided via below ground service entries.

**Table A1: Networks with an MOP not exceeding 75mbar (LP Networks)**

Networks with a maximum operating pressure not exceeding 75mbar (Low pressure Networks)				
Nominal Meter Installation standard and model	Emergency Control Valve			
	Nominal Size	Type	Specification	Outlet connection
	mm			
IGE/GM/6, U16	50	Ball	BS EN 331 MOP 0.5 Bar	External thread to BS746
IGE/GM/6, U25	50	Plug	BS 1552* MOP Class 200 mbar	External thread to BS746
IGE/GM/6, U40	50			
IGE/GM/6, U65	80	Gate Valve Double Block and Bleed	V 7 /E Part 1	BS EN 1092 – 1 - Table 9 PN 16 type B1 (raised face)
IGE/GM/6, U100	80			
IGE/GM/6, U160	80			
IGE/GM/6, U160	100			
IGE/GM/6, RD1	50	Plug	BS 1552* MOP Class 200 mbar	External thread to BS746
IGE/GM/6, RD2	80	Gate Valve Double Block and Bleed	V 7 /E Part 1	BS EN 1092 – 1 - Table 9 PN 16 type B1 (raised face)
IGE/GM/6, RD3				
IGE/GM/6, RD4	100	Gate Valve Double Block and Bleed	V 7 /E Part 1	BS EN 1092 – 1 - Table 9 PN 16 type B1 (raised face)
IGE/GM/6, RD5				
IGE/GM/6, RD6	150	Gate Valve Double Block and Bleed	V 7 /E Part 1	BS EN 1092 – 1 - Table 9 PN 16 type B1 (raised face)
IGE/GM/6, RD7				
IGE/GM/6, RD8				

\* Denotes BS EN 331 can be used as an alternative.

**Table A2: Networks with an MOP exceeding 75mbar and not exceeding 2bar. (MP Networks)**

Note: The ball valves referenced in Table A2 shall not be used for low-pressure installations.

Networks with a maximum operating pressure exceeding 75mbar and not exceeding 2bar. (Medium pressure Networks)				
Emergency Control Valve				
Nominal meter Installation standard and model	Nominal Size mm	Type	Specification	Outlet connection
IGE/TD/15	20	Ball	BS EN 331 MOP Class 5 Bar	BS EN 10806
IGE/GM/8	25 - 50	Ball	BS EN 331 MOP Class 5 Bar	BS21
IGE/GM/8	80 - 400	Gate Valve Double Block and Bleed	V 7 /E Part 1	BS EN 1092 – 1 - Table 9 PN 16 type B1 (raised face)

**Table A3: Networks with an MOP exceeding 2 bar and not exceeding 7 bar. (IP Networks)**

Note: The IGE/GL/5 process shall be used to support IP service planning and construction.

Networks with a maximum operating pressure exceeding 2bar and not exceeding 7 bar. (Intermediate pressure Networks)				
Emergency Control Valve				
Nominal meter Installation standard and model	Nominal Size mm	Type	Specification	Outlet connection
IGE/GM/8	20 - 50	Ball	BS 5159	BS EN 1092 – 1 - Table 9 PN 16 type B1 (raised face)
IGE/GM/8	80 - 400	Gate Valve Double Block and Bleed	V 7 /E Part 1	BS EN 1092 – 1 - Table 9 PN 16 type B1 (raised face)

## APPENDIX A – REFERENCES

This Specification refers to the documents listed below

NGN/SP/NP/14	-	Specification for the design of system extensions, connections and services to below 7 bar NGN Systems
SP/V/7 E	-	Technical specification for distribution valves
BS EN 331: 1998	-	Manually operated ball valves and closed bottom taper plug valves for gas installations in buildings
BS EN 1092 – 1: 2002	-	Flanges and their joints. Circular flanges for pipes, valves, fittings and accessories, PN designated. Steel flanges
BS EN ISO 10806:2003	-	Pipework. Fittings for corrugated metal hoses
BS 21: 1985	-	Specification for pipe threads for tubes and fittings where pressure-tight joints are made on the threads (metric dimensions)
BS 746: 1991	-	Specification for electrical safety of domestic gas appliances
BS 1552: 1995	-	Specification for open bottomed taper plug valves for 1st, 2 <sup>nd</sup> and 3 <sup>rd</sup> family gases up to 200 mbar
BS 5159: 1974	-	Specification for cast iron and carbon steel ball valves for general purposes
BS 6400 – 1: 2002	-	Specification for installation of domestic-sized gas meters maximum rated capacity not exceeding 6 m <sup>3</sup> /h (2 <sup>nd</sup> and 3 <sup>rd</sup> family gases). Low pressure (2 <sup>nd</sup> family gases)
IGE/GM/6	-	Specification for Low Pressure Diaphragm and Rotary Displacement Meter Installations with Badged Meter Capacities exceeding 1076 m <sup>3</sup> /h (38000 ft <sup>3</sup> /h)
IGE/GM/8	-	Meter Installations – I&C
IGE/TD/3	-	Steel and PE Pipelines for Gas Distribution (With amendments May 2003)
IGE/TD/4	-	Gas Services
IGE/GL/5	-	Plant Modification Procedures (With amendments, January 1999) GS (I&U) Regs - The Gas Safety (Installation and Use) (Amendment) Regulations 1996

## APPENDIX B – DEFINITIONS

The definitions applying to this specification are given below (see clause **Error! Reference source not found.**).

### B.1 Enter heading for Definition subject group

<b>ECV</b>	-	Emergency Control Valve
<b>Enter term used</b>	-	Enter text defining the term

*Uncontrolled when printed.  
Complies with GRM.*

**APPENDIX C – SPECIFICATION AND DETAILS OF ECV INSTALLATION**

**Valve Orientation for Vertical Inlet**  
(Plan View)

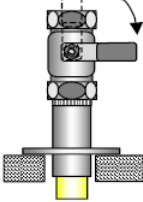
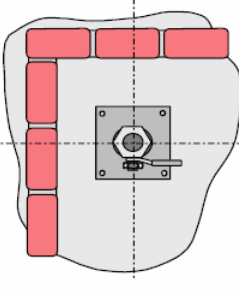
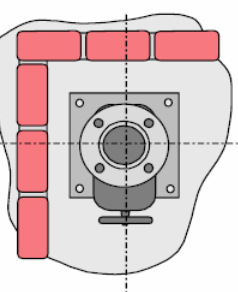
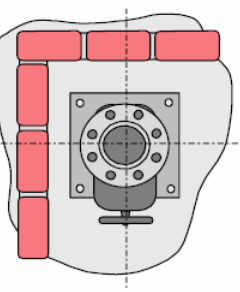
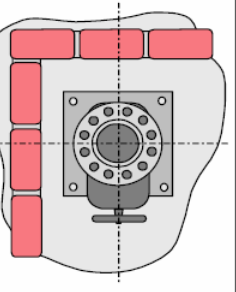
<p><b>NOTE</b> Valves with levers must fall to close</p> 					
	Service Valve Size	Up to 50mm	Up to 50mm	80mm, 100mm and 150mm	200mm, 250mm and 300mm
	Valve Type	SCREWED	FLANGED	FLANGED	FLANGED
	No Bolts	N/A	4	8	12
	Bolt size	N/A	M16	80mm/100mm – M16 150mm – M20	200mm – M20 250mm/300mm – M24

**Valve Orientation for Horizontal Inlet**  
(End View)

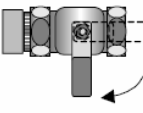
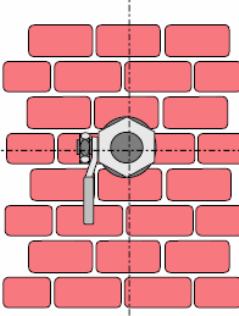
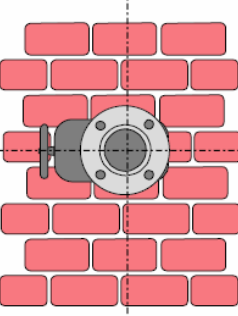
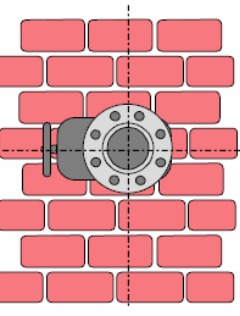
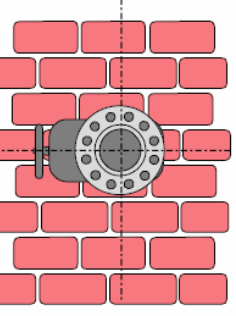
<p><b>NOTE</b> Valves with levers must fall to close</p> 					
	Service Valve Size	Up to 50mm	Up to 50mm	80mm, 100mm and 150mm	200mm, 250mm and 300mm
	Valve Type	SCREWED	FLANGED	FLANGED	FLANGED
	No Bolts	N/A	4	8	12
	Bolt size	N/A	M16	80mm/100mm – M16 150mm – M20	200mm – M20 250mm/300mm – M24

**Horizontal Inlet Connection Heights for LP/MP**

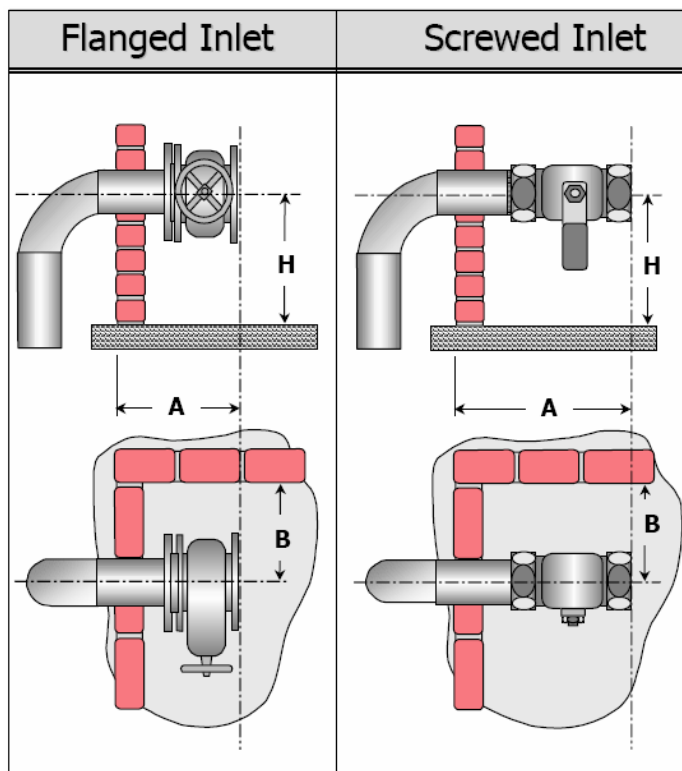

Horizontal Inlet					
Size of ECV "D" Ø	Pressure Tier	Connection Type	Dim A Minimum distance	Dim B Minimum distance	Dim H Tolerance ± 25mm
≤ 50mm	LP / MP	SCREWED	440	300	600
80mm	LP / MP	FLANGED	625	350	800
100mm	LP / MP	FLANGED	650	350	800
150mm	LP / MP	FLANGED	880	450	800

**Pressure Tier**

LP = Low Pressure not exceeding 75 mbar  
 MP = Medium Pressure not exceeding 2bar

**NOTE**

**IP –ABOVE GROUND ENTRY NOT TO BE USED VERTICAL  
 BELOW GROUND INLET ONLY**

**DIMENSION "A" IS TO OUTSIDE OF WALL**

**Vertical Inlet Connection Heights for LP/MP/IP**

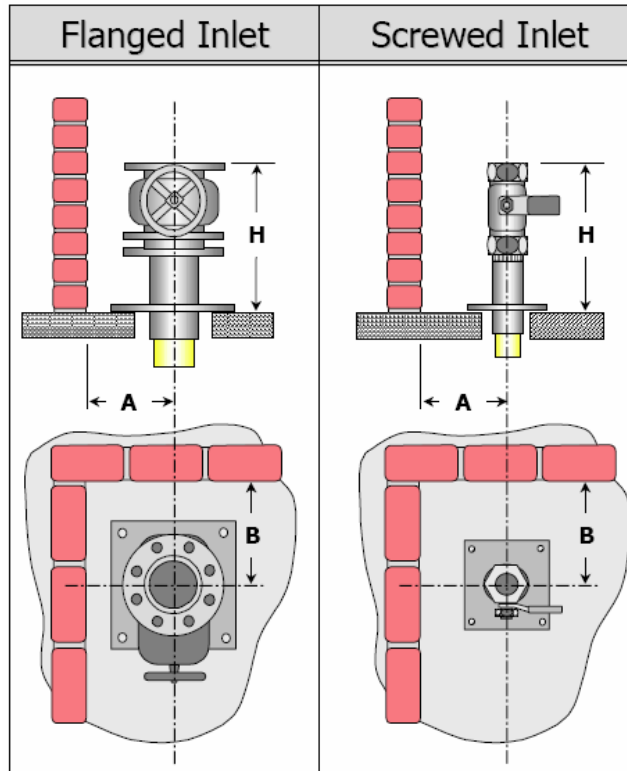

Vertical Inlet					
Size of ECV "D" Ø	Pressure Tier	Connection Type	Dim A Minimum distance	Dim B Minimum distance	Dim H Tolerance ± 25mm
≤ 50mm	LP / MP	SCREWED	2D	300	265
≤ 50mm	IP	FLANGED	2D	350	350
80mm - 100mm	LP / MP / IP	FLANGED	2D	350	500
150mm	LP / MP / IP	FLANGED	2D	450	500
> 150mm	LP / MP / IP	FLANGED	2D	750	550

**Example of Dim A**

80mm PN16 ECV - Dim A = 2 x 80mm = 160mm

**Pressure Tier**

- LP = Low Pressure not exceeding 75 mbar
- MP = Medium Pressure not exceeding 2bar
- IP = Intermediate Pressure not exceeding 7bar

**Positioning Vertical Inlet in Concrete Slotted Bases**

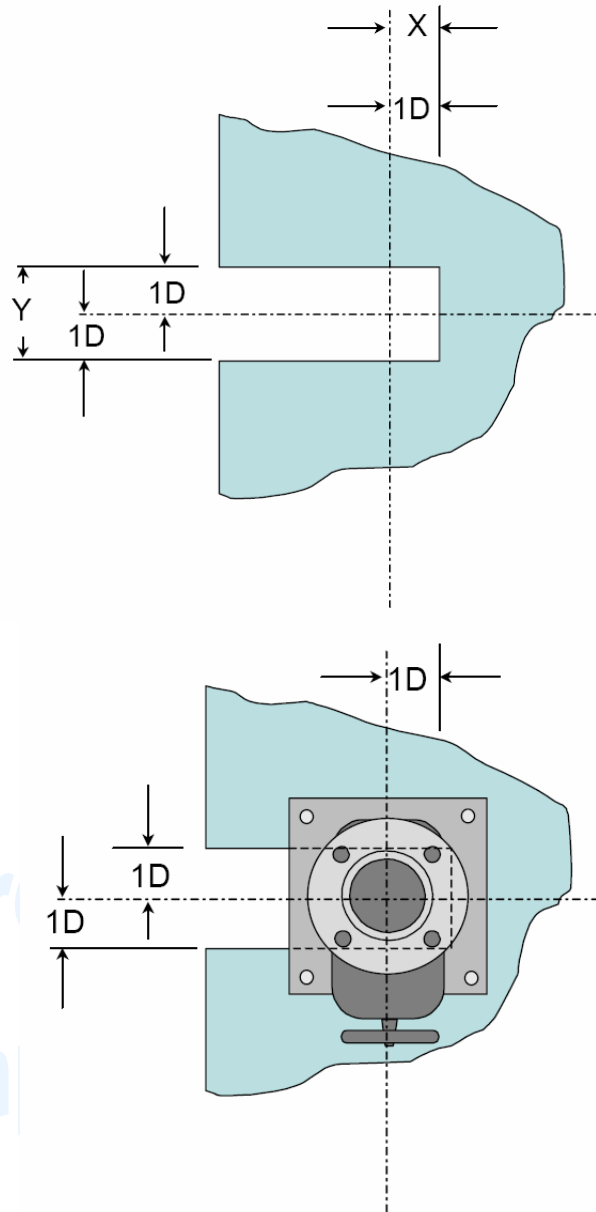

**Example 50mm Vertical Inlet**

$Y = \text{Slot Width } 1D + 1D = 50\text{mm} + 50\text{mm} = 100\text{mm}$

$X = \text{Central position from end of slot} = 1D = 50\text{mm}$

**Example of Steel / Transition Fittings**

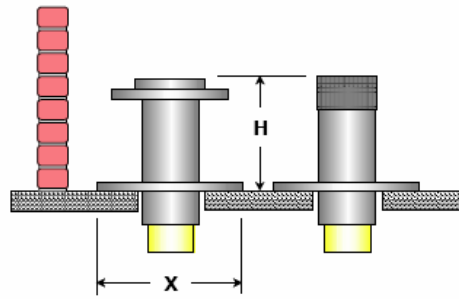

**Base Plate Square**

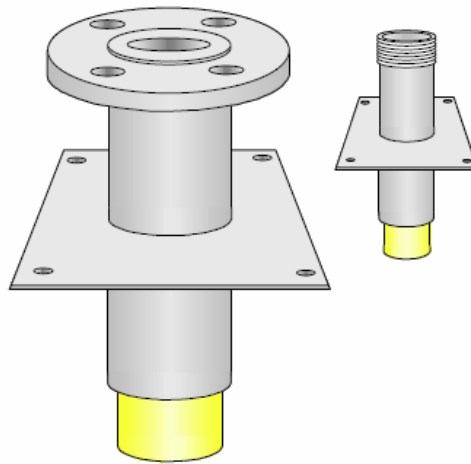

Flange Size	Dim H	Dim X
50mm	170mm	250mm
80mm	295mm	310mm
100mm	269mm	350mm
150mm	231mm	450mm
200mm	256mm	550mm
250mm	218mm	650mm
300mm	192mm	750mm

Threaded Size	Dim H	Dim X
25mm	170mm	200mm
50mm	170mm	250mm

**Note: The square base plate shown is not a puddle flange and represents the anchorage to be used to ensure the stability of the riser**